

Technical Data Sheet

ENGINEERING
TOMORROW



Compressor model **NPT16LR**
 Voltage **115-127V 60Hz ~1**
 Refrigerant **R290**
 Compressor status

APPLICATION		COMPRESSOR	MOTOR
Application	Low Back Pressure	Displacement	16,10 cm ³
Refrigerant	R290	Diameter	31,19 mm
Evaporating Temp.	-40,0 °C to -10,0 °C	Stroke	21,13 mm
Expansion	Capillar/Valve	Net Weight	12,70 Kg
Comp. Cooling	Fan cooled	Oil type	ISO VG 32 ESTER
Max. ambient temp.	43,0 °C	Oil charge	400 cm ³
		HP	1/2 hp
		Voltage/Frequency	115-127V 60Hz
		Voltage range	98-140 V
		Type	CSR
		Phase number	1 PH
		Locked Rotor Amps (LRA)	43,00 A
		Max. Cont. Current (MCC)	8,80 A
		Main W. resist. at 25°C	0,84 Ω
		Start W. resist. at 25°C	5,12 Ω

NOMINAL PERFORMANCE

	ASHRAE	CECOMAF
Cooling Capacity	737 kCal/h	637 W
COP	1,42 W/W	1,10 W/W
EER	1,22 kCal/Wh	0,95 kCal/Wh
Input Power	604 W	581 W
Current	5,42 A	5,22 A

APPROVALS



TEST CYCLE CONDITIONS

	ASHRAE LBP (B)	CECOMAF LBP (A)
Evaporating temp. (T _e)	-23,3 °C	-25,0 °C
Condensing temp. (T _c)	55,0 °C	55,0 °C
Liquid temp. (T _{liq.})	32,0 °C	55,0 °C
Ambient temp. (T _{amb.})	32,0 °C	32,0 °C
Suction temp. (T _{suction})	32,0 °C	32,0 °C
Voltage/Frequency	115 V 60 Hz	115 V 60 Hz

ELECTRICAL COMPONENTS

Starting capacitor	200 µF 160 V		
Run capacitor	30 µF 250 V		
Relay	Option 1	Option 2	
Reference	2014 191. + NTC3î©	QLZ-24.4A + NTC3î©	
Pick-Up	24,40 A	24.4 A	
Drop-Out	20,30 A	20.3 A	
Protector	Option 1		
Reference	T0534		
Current	20,00 A		
Time check	7,5-14 seg		
Disc temp. (Open/Close)	105,00 / 52,00 °C		

This product is approved for R290 and R600a regarding explosion safety according to standard EN 60335-1 and EN 60335-2-34



ASHRAE

Tc °C	Te °C	Cooling Capacity kCal/h	Consumption W	Current A	COP W/W	EER kCal/Wh
40	-40	350	397	3,64	1,02	0,88
40	-35	450	438	3,99	1,19	1,03
40	-30	581	484	4,38	1,40	1,20
40	-25	743	536	4,83	1,61	1,39
40	-23,3	806	554	4,99	1,69	1,45
40	-20	936	592	5,32	1,84	1,58
40	-15	1.161	654	5,86	2,06	1,77
40	-10	1.416	721	6,46	2,28	1,96

45	-40	335	398	3,65	0,98	0,84
45	-35	433	444	4,04	1,13	0,98
45	-30	562	495	4,47	1,32	1,14
45	-25	721	551	4,95	1,52	1,31
45	-23,3	783	571	5,13	1,59	1,37
45	-20	912	612	5,49	1,73	1,49
45	-15	1.134	678	6,07	1,94	1,67
45	-10	1.386	750	6,72	2,15	1,85

50	-40	321	399	3,66	0,93	0,80
50	-35	416	449	4,09	1,08	0,93
50	-30	542	505	4,56	1,25	1,07
50	-25	699	566	5,09	1,44	1,24
50	-23,3	760	587	5,28	1,50	1,29
50	-20	887	632	5,66	1,63	1,41
50	-15	1.107	703	6,29	1,83	1,57
50	-10	1.357	779	6,98	2,03	1,74

55	-40	306	400	3,67	0,89	0,77
55	-35	399	455	4,13	1,02	0,88
55	-30	523	515	4,65	1,18	1,01
55	-25	677	581	5,22	1,36	1,17
55	-23,3	737	604	5,42	1,42	1,22
55	-20	863	651	5,83	1,54	1,33
55	-15	1.080	727	6,51	1,73	1,48
55	-10	1.327	808	7,24	1,91	1,64

60	-40	292	401	3,68	0,85	0,73
60	-35	382	461	4,18	0,96	0,83
60	-30	503	526	4,74	1,11	0,96
60	-25	655	596	5,35	1,28	1,10
60	-23,3	714	621	5,57	1,34	1,15
60	-20	838	671	6,01	1,45	1,25
60	-15	1.053	751	6,73	1,63	1,40
60	-10	1.298	837	7,50	1,80	1,55

CECOMAF

Tc °C	Te °C	Cooling Capacity W	Consumption W	Current A	COP W/W	EER kCal/Wh
40	-40	379	397	3,64	0,95	0,82
40	-35	500	438	3,99	1,14	0,99
40	-30	650	484	4,38	1,34	1,16
40	-25	829	536	4,83	1,55	1,34
40	-23,3	896	554	4,99	1,62	1,40
40	-20	1.036	592	5,32	1,75	1,51
40	-15	1.273	654	5,86	1,95	1,68
40	-10	1.538	721	6,46	2,13	1,84

45	-40	349	398	3,65	0,88	0,76
45	-35	459	444	4,04	1,03	0,89
45	-30	598	495	4,47	1,21	1,04
45	-25	765	551	4,95	1,39	1,20
45	-23,3	828	571	5,13	1,45	1,25
45	-20	961	612	5,49	1,57	1,36
45	-15	1.186	678	6,07	1,75	1,51
45	-10	1.440	750	6,72	1,92	1,66

50	-40	319	399	3,66	0,80	0,69
50	-35	417	449	4,09	0,93	0,80
50	-30	545	505	4,56	1,08	0,93
50	-25	701	566	5,09	1,24	1,07
50	-23,3	761	587	5,28	1,30	1,12
50	-20	886	632	5,66	1,40	1,21
50	-15	1.100	703	6,29	1,57	1,35
50	-10	1.342	779	6,98	1,72	1,49

55	-40	288	400	3,67	0,72	0,62
55	-35	376	455	4,13	0,83	0,71
55	-30	492	515	4,65	0,96	0,83
55	-25	637	581	5,22	1,10	0,95
55	-23,3	693	604	5,42	1,15	0,99
55	-20	811	651	5,83	1,25	1,08
55	-15	1.013	727	6,51	1,39	1,20
55	-10	1.244	808	7,24	1,54	1,33

60	-40	258	401	3,68	0,64	0,56
60	-35	334	461	4,18	0,73	0,63
60	-30	439	526	4,74	0,84	0,72
60	-25	573	596	5,35	0,96	0,83
60	-23,3	625	621	5,57	1,01	0,87
60	-20	736	671	6,01	1,10	0,95
60	-15	927	751	6,73	1,23	1,07
60	-10	1.147	837	7,50	1,37	1,18

EN12900

X	Cooling Capacity (W)	Consumption (W)	Current (A)	Mass Flow (kg/h)
1	3.102,5146004783	579,2556242004	5,1730166527	28,936988429789
2	84,5659113731	8,9073382727	0,0830447259	0,90634636439433
3	-24,7180644857	7,8563646206	0,0713549656	-0,087012636979633
4	0,5600913972	0,1090423637	0,0011231777	0,0081282429311216
5	-0,4650704554	0,1913007624	0,0017408632	-0,0012883030543214

Equation	$x_1 + x_2Te + x_3Tc + x_4Te^2 + x_5TeTc$
----------	---

COMPRESSOR DIMENSIONS

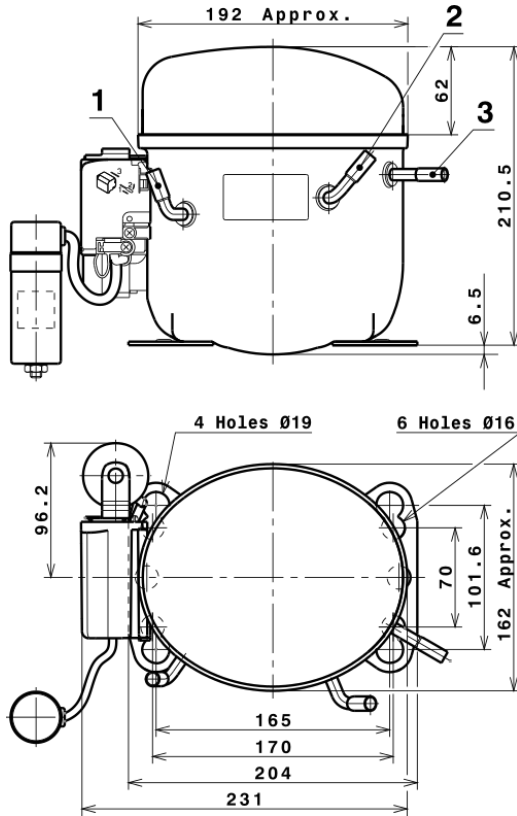

DESIGNATION INTERNAL DIAM.

DESIGNATION	INTERNAL DIAM.
1	Suction 8,1 mm
2	Service 8,1 mm
3	Discharge 6,5 mm

WIRING DIAGRAMS AND ELECTRICAL ASSEMBLY

CSR CONNECTION (CURRENT RELAY + NTC) (L, P ranges)

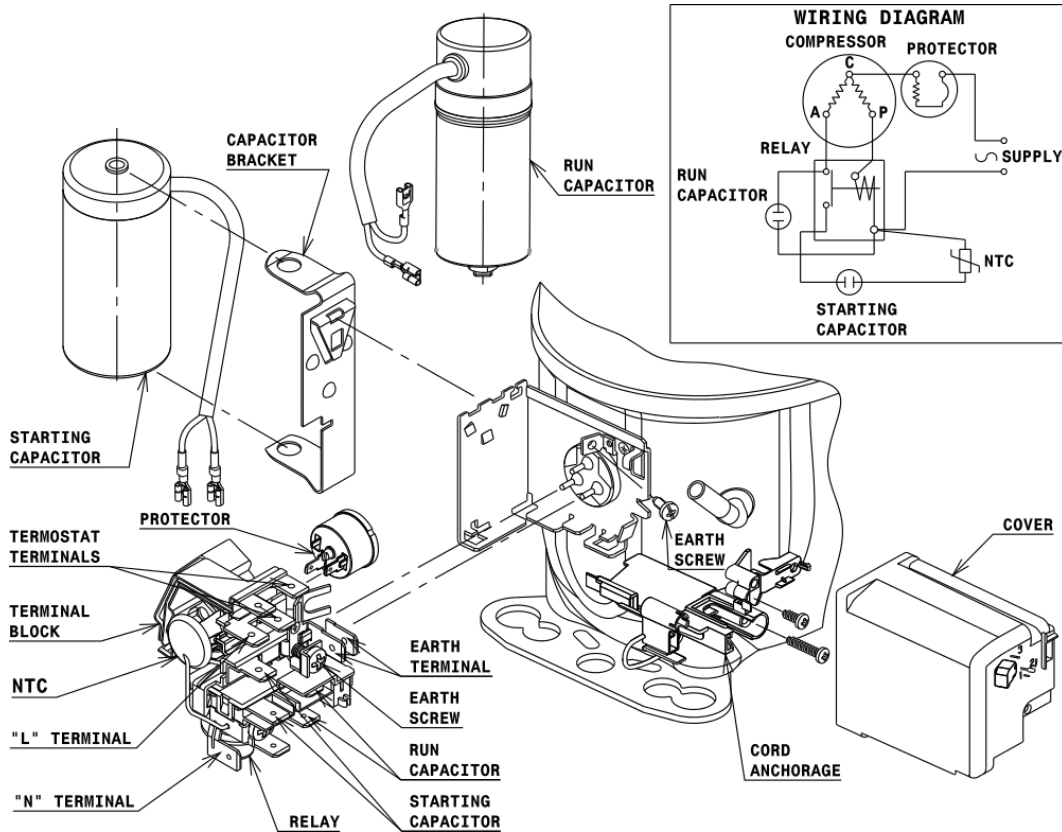

FIXINGS

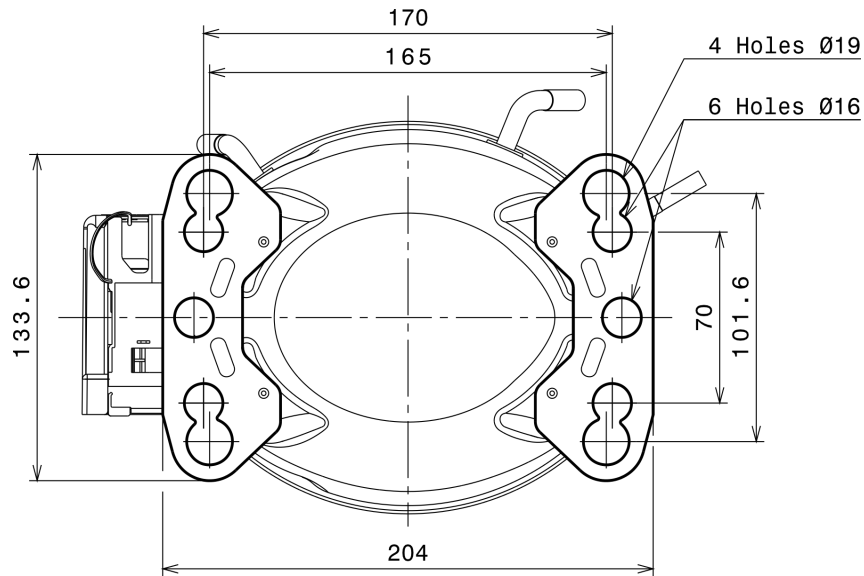

SILENT BLOCKS (MOUNTING ACCESSORIES)

STANDARD

$\varnothing 16$ holes (170x70 net)

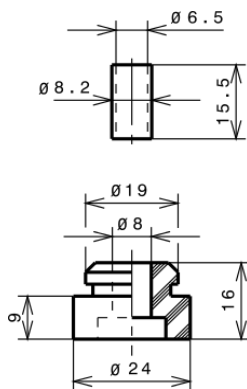

AMERICAN FEET

$\varnothing 19$ holes (165x101.6 net)

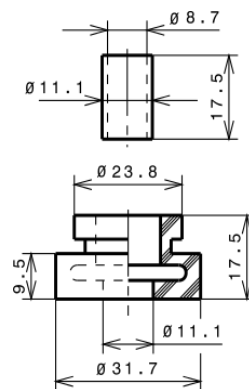

SNAP-ON

$\varnothing 16$ holes (170x70 net)

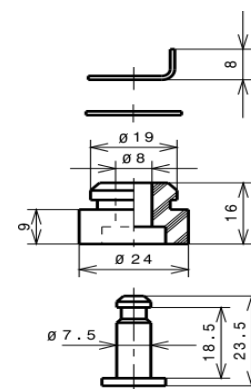

SOA

SOA R290 LBP

